

EMBEDDED POLE SERIES

固封极柱系列

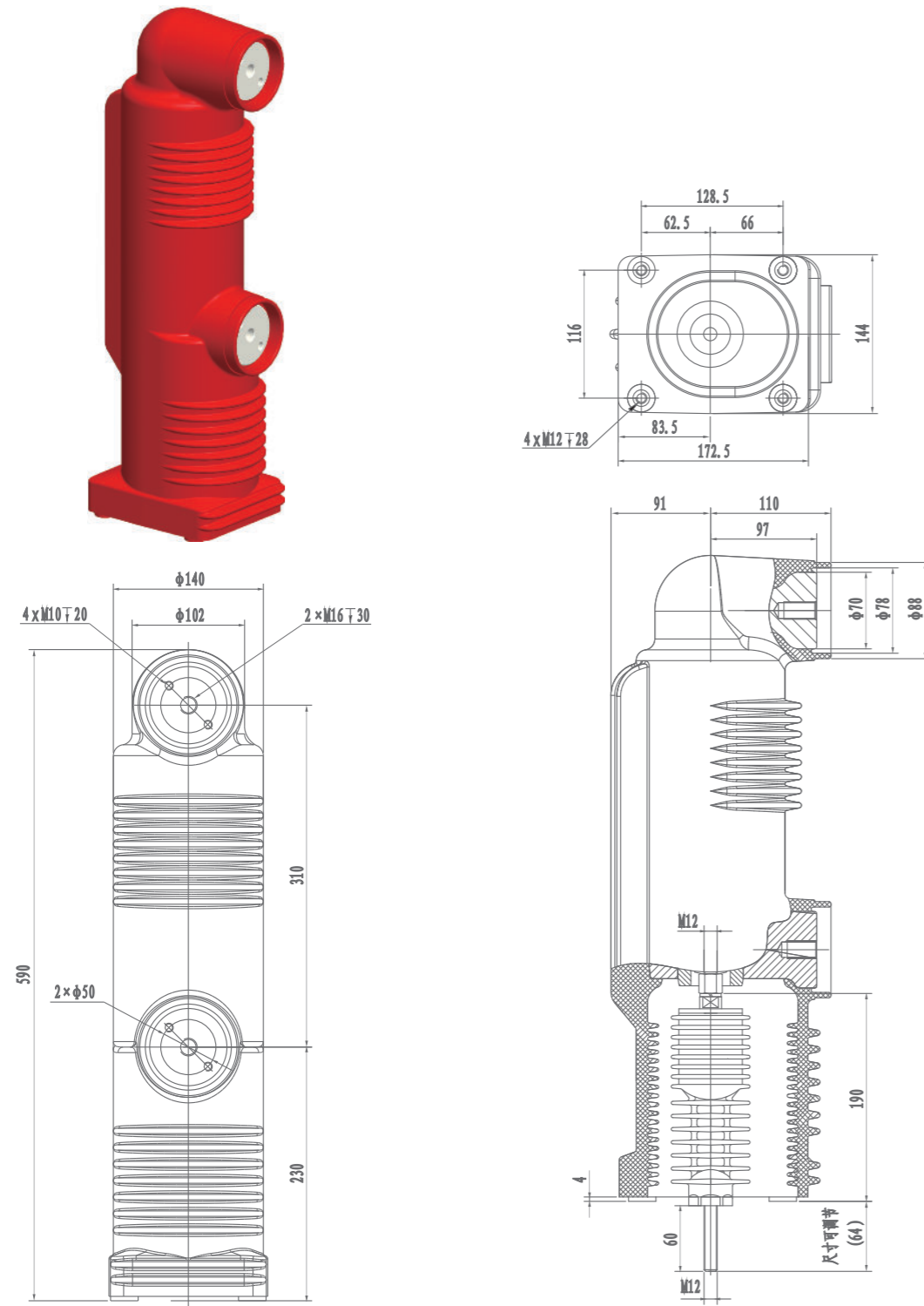

图号 Drawing No.	规格型号 Specification	配用绝缘拉杆 Match The Insulated Pull Rod	配用触臂套 Match The Contact Arm Sleeve
RZP5.028a	EP24/2000-31.5	RAP4.028c.05	RAP4.028a.11

EMBEDDED POLE SERIES

固封极柱系列

主要技术参数 Main Technical Data

参数	Parameter	数值 Value	单位 Unit
额定电压	Rated Voltage	24	kV
额定电流	Rated Current	2000	A
额定频率	Rated Frequency	50	Hz
额定短路开断电流	Rated Short-circuit Breaking Current	31.5	kA
额定短路开断电流的开断次数	Operations Of Short-circuit Breaking Current Interruption	30	次
额定短路关合电流	Rated Short-circuit Making Current	80	kA
额定峰值耐受电流	Rated Peak Withstand Current	80	kA
额定短时耐受电流 (4秒)	Rated Short-time Withstand Current (4s)	31.5	kA
额定单个电容器组开断电流	Rated Single Capacitor Bank Breaking Current	630※	A
额定背对背电容器组开断电流	Rated Back-to-back Capacitor Breaking Current	400※	A
短时 (1分钟) 工频耐受电压	Short-time(1min)power-frequency Withstand Voltage	65	kV
雷电冲击耐受电压 (峰值)	Lighting Impulse Withstand Voltage(peak)	125	kV
额定触头压力下的回路电阻	Circuit Resistance At Rated Contact Force	≤21	μΩ
机械寿命	Mechanical Life	10,000	次
触头自闭力	Contact Closing Force Due To Bellows And Atmosphere	120±50	N
额定开距下的触头反力	Counterforce At Rated Contact Stroke	200±50	N
触头允许磨损厚度	Contact Limit Erosion	3	mm
贮存期	Shelf Life	20	年
局部放电值	Partial Discharge	≤1	pC
额定操作顺序	Rated Operating Sequence	0-0.3s-co-180s-co	

配套的真空开关应满足的机械参数 Mechanical Data Of Circuit Equipped With Interrupters

参数	Parameter	数值 Value	单位 Unit
触头开距	Rated Contact Stroke	12±1	mm
触头接触行程	Contact Connection Stroke	3±1	mm
平均分闸速度	Average Opening Speed	1.1~1.5	m/s
平均合闸速度	Average Closing Speed	0.4~0.8	m/s
额定触头压力	Rated Operation Pressure Of Contact	3100±200	N
触头合闸弹跳时间	Bounce Duration Of Contact Closing	≤2	ms
触头分闸不同期	Out Of Simultaneity Of Contact Closing And Opening	≤1	ms
分闸触头反弹幅值	Max.overtravel	≤2	mm

注：标“※”项为需要时提供的参数。“※”Rated characteristics to be given on request

EMBEDDED POLE SERIES

固封极柱系列

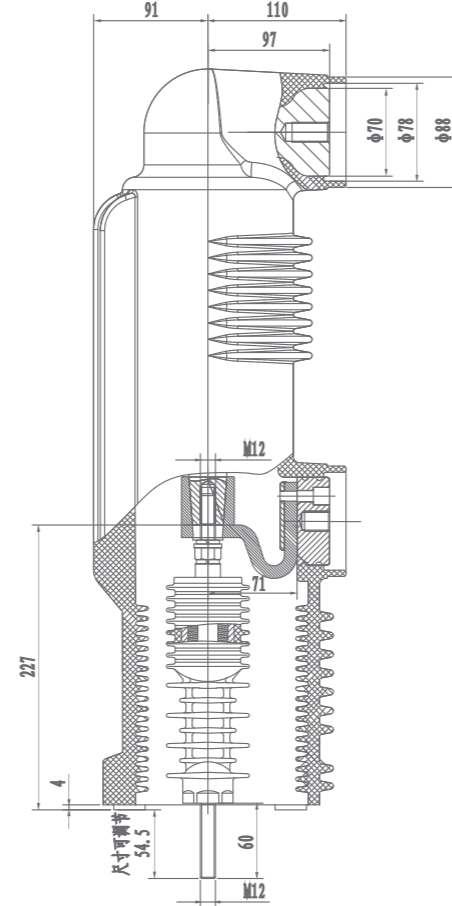
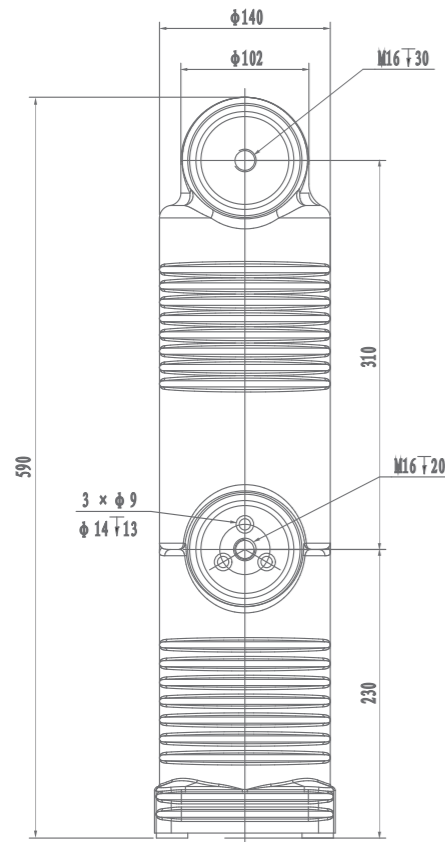
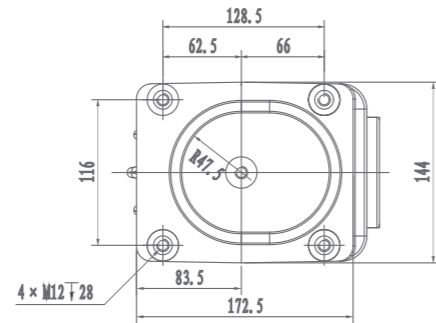
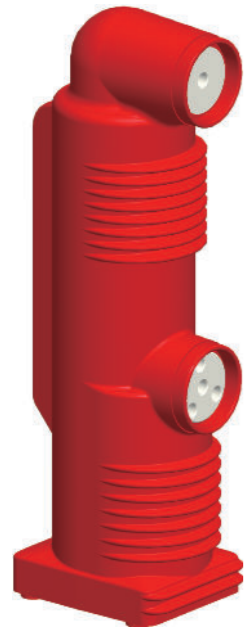

图号 Drawing No.	规格型号 Specification	配用绝缘拉杆 Match The Insulated Pull Rod	配用软连接 Match The Flexible Connection	配用触臂套 Match The Contact Arm Sleeve
RZP5. 028b	EP24/1600-31.5	RAP4. 028c. 05	RAP4. 028b. 01	RAP4. 028b. 11

EMBEDDED POLE SERIES

固封极柱系列

主要技术参数 Main Technical Data

参数	Parameter	数值 Value	单位 Unit
额定电压	Rated Voltage	24	kV
额定电流	Rated Current	1600	A
额定频率	Rated Frequency	50	Hz
额定短路开断电流	Rated Short-circuit Breaking Current	31.5	kA
额定短路开断电流的开断次数	Operations Of Short-circuit Breaking Current Interruption	30	次
额定短路关合电流	Rated Short-circuit Making Current	80	kA
额定峰值耐受电流	Rated Peak Withstand Current	80	kA
额定短时耐受电流 (4秒)	Rated Short-time Withstand Current (4s)	31.5	kA
额定单个电容器组开断电流	Rated Single Capacitor Bank Breaking Current	630※	A
额定背对背电容器组开断电流	Rated Back-to-back Capacitor Breaking Current	400※	A
短时 (1分钟) 工频耐受电压	Short-time(1min)power-frequency Withstand Voltage	65	kV
雷电冲击耐受电压 (峰值)	Lighting Impulse Withstand Voltage(peak)	125	kV
额定触头压力下的回路电阻	Circuit Resistance At Rated Contact Force	≤23	μΩ
机械寿命	Mechanical Life	10,000	次
触头自闭力	Contact Closing Force Due To Bellows And Atmosphere	120±50	N
额定开距下的触头反力	Counterforce At Rated Contact Stroke	200±50	N
触头允许磨损厚度	Contact Limit Erosion	3	mm
贮存期	Shelf Life	20	年
局部放电值	Partial Discharge	≤1	pC
额定操作顺序	Rated Operating Sequence	0-0.3s-co-180s-co	

配套的真空开关应满足的机械参数 Mechanical Data Of Circuit Equipped With Interrupters

参数	Parameter	数值 Value	单位 Unit
触头开距	Rated Contact Stroke	12±1	mm
触头接触行程	Contact Connection Stroke	3±1	mm
平均分闸速度	Average Opening Speed	1.1~1.5	m/s
平均合闸速度	Average Closing Speed	0.4~0.8	m/s
额定触头压力	Rated Operation Pressure Of Contact	3100±200	N
触头合闸弹跳时间	Bounce Duration Of Contact Closing	≤2	ms
触头分闸不同期	Out Of Simultaneity Of Contact Closing And Opening	≤1	ms
分闸触头反弹幅值	Max.overtravel	≤2	mm

注：标“※”项为需要时提供的参数。“※”Rated characteristics to be given on request

EMBEDDED POLE SERIES

固封极柱系列

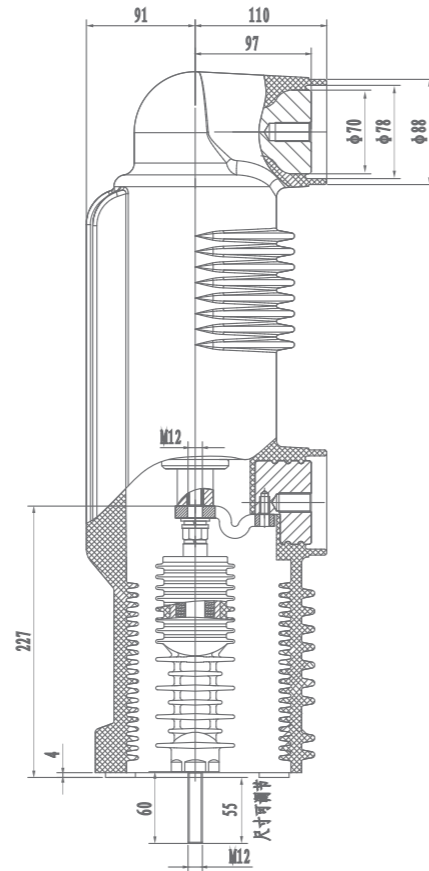
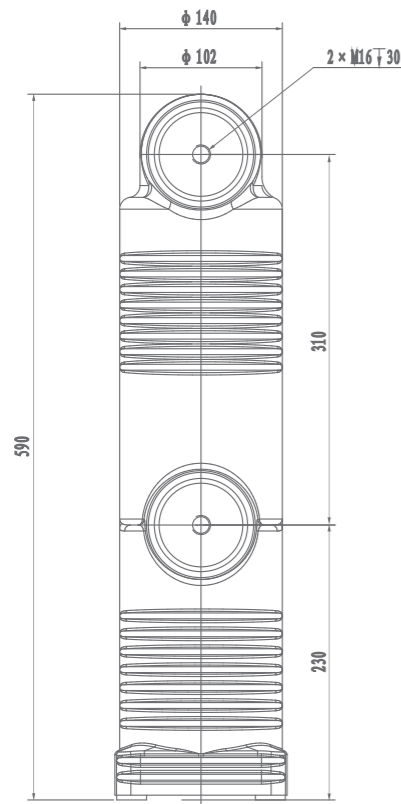
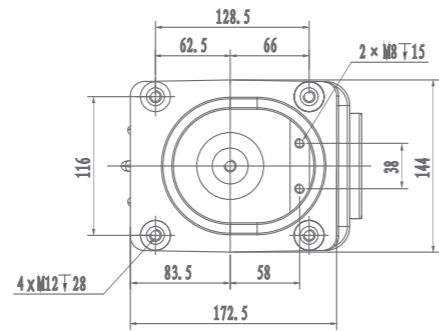

图号 Drawing No.	规格型号 Specification	配用绝缘拉杆 Match The Insulated Pull Rod	配用软连接 Match The Flexible Connection	配用触臂套 Match The Contact Arm Sleeve
RZP5. 028c	EP24/ 1250-31.5	RAP4. 028c. 05	RAP4. 028c. 01	RAP4. 028c. 11

EMBEDDED POLE SERIES

固封极柱系列

主要技术参数 Main Technical Data

参数	Parameter	数值 Value	单位 Unit
额定电压	Rated Voltage	24	kV
额定电流	Rated Current	1250	A
额定频率	Rated Frequency	50	Hz
额定短路开断电流	Rated Short-circuit Breaking Current	31.5	kA
额定短路开断电流的开断次数	Operations Of Short-circuit Breaking Current Interruption	30	次
额定短路关合电流	Rated Short-circuit Making Current	80	kA
额定峰值耐受电流	Rated Peak Withstand Current	80	kA
额定短时耐受电流 (4秒)	Rated Short-time Withstand Current (4s)	31.5	kA
额定单个电容器组开断电流	Rated Single Capacitor Bank Breaking Current	630※	A
额定背对背电容器组开断电流	Rated Back-to-back Capacitor Breaking Current	400※	A
短时 (1分钟) 工频耐受电压	Short-time(1min)power-frequency Withstand Voltage	65	kV
雷电冲击耐受电压 (峰值)	Lighting Impulse Withstand Voltage(peak)	125	kV
额定触头压力下的回路电阻	Circuit Resistance At Rated Contact Force	≤25	μΩ
机械寿命	Mechanical Life	10,000	次
触头自闭力	Contact Closing Force Due To Bellows And Atmosphere	120±50	N
额定开距下的触头反力	Counterforce At Rated Contact Stroke	200±50	N
触头允许磨损厚度	Contact Limit Erosion	3	mm
贮存期	Shelf Life	20	年
局部放电值	Partial Discharge	≤1	pC
额定操作顺序	Rated Operating Sequence	0-0.3s-co-180s-co	

配套的真空开关应满足的机械参数 Mechanical Data Of Circuit Equipped With Interrupters

参数	Parameter	数值 Value	单位 Unit
触头开距	Rated Contact Stroke	12±1	mm
触头接触行程	Contact Connection Stroke	3±1	mm
平均分闸速度	Average Opening Speed	1.1~1.5	m/s
平均合闸速度	Average Closing Speed	0.4~0.8	m/s
额定触头压力	Rated Operation Pressure Of Contact	3100±200	N
触头合闸弹跳时间	Bounce Duration Of Contact Closing	≤2	ms
触头分闸不同期	Out Of Simultaneity Of Contact Closing And Opening	≤1	ms
分闸触头反弹幅值	Max.overtravel	≤2	mm

注：标“※”项为需要时提供的参数。“※”Rated characteristics to be given on request