

EMBEDDED POLE SERIES

固封极柱系列

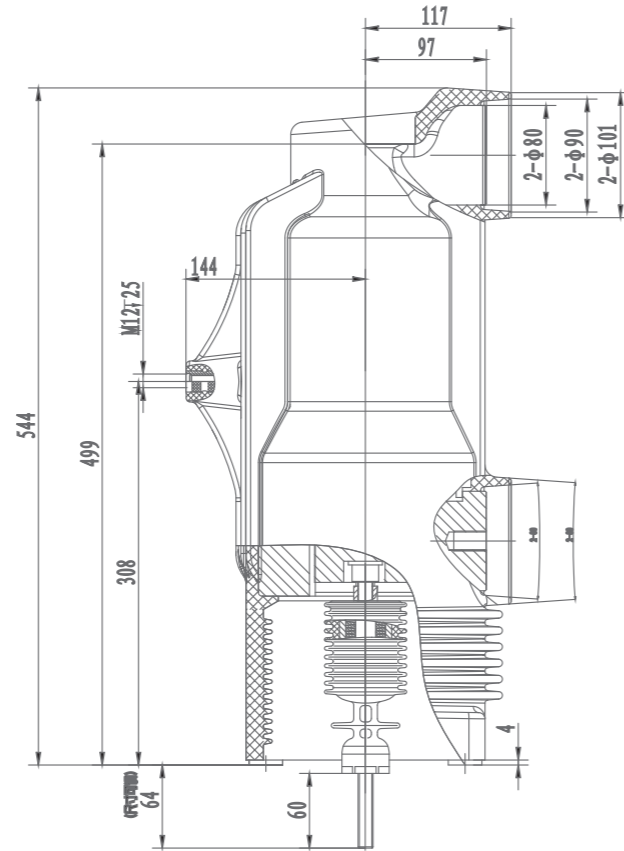
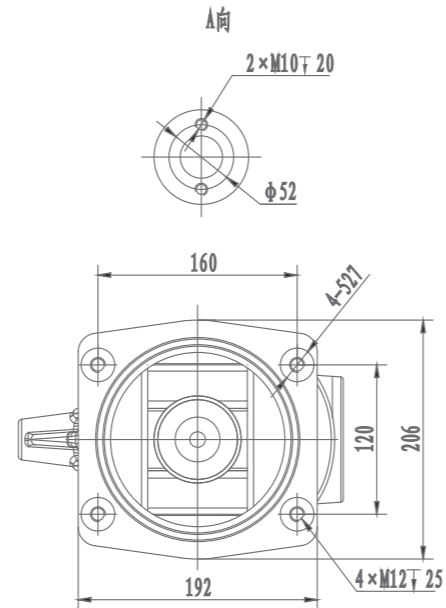
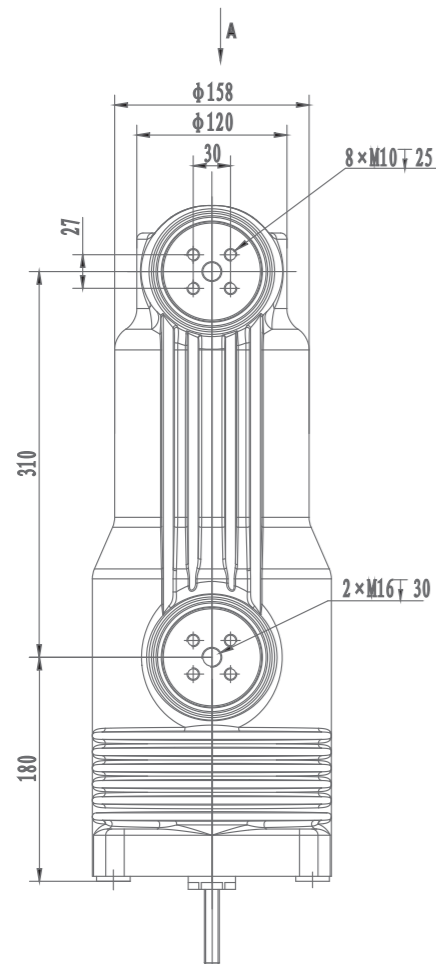
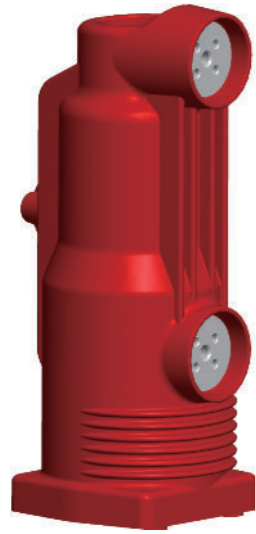

图号 Drawing No.	规格型号 Specification	配用绝缘拉杆 Match The Insulated Pull Rod	配用触臂套 Match The Contact Arm Sleeve
RZP5.110u	EP12/3150-40	RAP4.076b.08	RAP4.110b.11

EMBEDDED POLE SERIES

固封极柱系列

主要技术参数 Main Technical Data

参数	Parameter	数值 Value	单位 Unit
额定电压	Rated Voltage	12	kV
额定电流	Rated Current	3150	A
额定频率	Rated Frequency	50	Hz
额定短路开断电流	Rated Short-circuit Breaking Current	40	kA
额定短路开断电流的开断次数	Operations Of Short-circuit Breaking Current Interruption	30	次
额定短路关合电流	Rated Short-circuit Making Current	100	kA
额定峰值耐受电流	Rated Peak Withstand Current	100	kA
额定短时耐受电流 (4秒)	Rated Short-time Withstand Current (4s)	40	kA
额定单个电容器组开断电流	Rated Single Capacitor Bank Breaking Current	630※	A
额定背对背电容器组开断电流	Rated Back-to-back Capacitor Breaking Current	400※	A
短时 (1分钟) 工频耐受电压	Short-time(1min)power-frequency Withstand Voltage	48	kV
雷电冲击耐受电压 (峰值)	Lighting Impulse Withstand Voltage(peak)	75	kV
额定触头压力下的回路电阻	Circuit Resistance At Rated Contact Force	≤ 13	$\mu\Omega$
机械寿命	Mechanical Life	10,000	次
触头自闭力	Contact Closing Force Due To Bellows And Atmosphere	250 \pm 60	N
额定开距下的触头反力	Counterforce At Rated Contact Stroke	340 \pm 60	N
触头允许磨损厚度	Contact Limit Erosion	3	mm
贮存期	Shelf Life	20	年
局部放电值	Partial Discharge	≤ 1	pC
额定操作顺序	Rated Operating Sequence	0-0.3s-co-180s-co	

配套的真空开关应满足的机械参数 Mechanical Data Of Circuit Equipped With Interrupters

参数	Parameter	数值 Value	单位 Unit
触头开距	Rated Contact Stroke	9 \pm 1	mm
触头接触行程	Contact Connection Stroke	3 \pm 1	mm
平均分闸速度	Average Opening Speed	1.3 \pm 0.2	m/s
平均合闸速度	Average Closing Speed	0.6 \pm 0.2	m/s
额定触头压力	Rated Operation Pressure Of Contact	5000 \pm 300	N
触头合闸弹跳时间	Bounce Duration Of Contact Closing	≤ 2	ms
触头分闸不同期	Out Of Simultaneity Of Contact Closing And Opening	≤ 1	ms
分闸触头反弹幅值	Max.overtravel	≤ 2	mm

注：标“※”项为需要时提供的参数。“※”Rated characteristics to be given on request